



PEEL™ 18CV8 -7/-10/-15/-25

CMOS Programmable Electrically Erasable Logic Device

Features

Multiple Speed Power, Temperature Options

- V_{CC} = 5 Volts ±10%
- Speeds ranging from 7ns to 25 ns
- Power as low as 37mA at 25MHz
- Commercial and industrial versions available

CMOS Electrically Erasable Technology

- Superior factory testing
- Reprogrammable in plastic package
- Reduces retrofit and development costs

Development / Programmer Support

- Third party software and programmers
- WinPLACE Development Software
- PLD-to-PEEL™ JEDEC file translator

Architectural Flexibility

- Enhanced architecture fits in more logic
- 74 product terms x 36 input AND array
- 10 inputs and 8 I/O pins
- 12 possible macrocell configurations
- Asynchronous clear
- Independent output enables
- 20 Pin DIP/SOIC/TSSOP and PLCC

Application Versatility

- Replaces random logic
- Super sets PLDs (PAL, GAL, EPLD)
- Enhanced Architecture fits more logic than ordinary PLDs

General Description

The PEEL™18CV8 is a Programmable Electrically Erasable Logic (PEEL™) device providing an attractive alternative to ordinary PLDs. The PEEL™18CV8 offers the performance, flexibility, ease of design and production practicality needed by logic designers today.

The PEEL™18CV8 is available in 20-pin DIP, PLCC, SOIC and TSSOP packages with speeds ranging from 7ns to 25ns with power consumption as low as 37mA. EE-Reprogrammability provides the convenience of instant reprogramming for development and reusable production inventory minimizing the impact of programming changes or errors. EE-Reprogrammability also improves factory testability, thus assuring the highest quality possible.

The PEEL™18CV8 architecture allows it to replace over 20 standard 20-pin PLDs (PAL, GAL, EPLD etc.). It also provides additional architecture features so more logic can be put into every design. Anachip's JEDEC file translator instantly converts to the PEEL™18CV8 existing 20-pin PLDs without the need to rework the existing design. Development and programming support for the PEEL™18CV8 is provided by popular third-party programmers and development software.

Figure 2 Pin Configuration

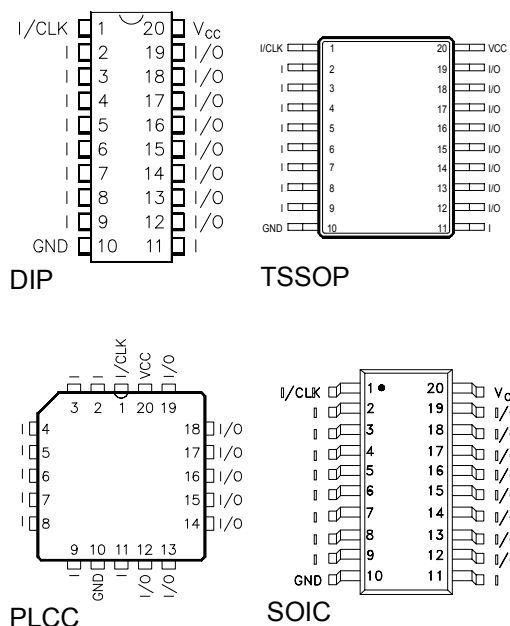
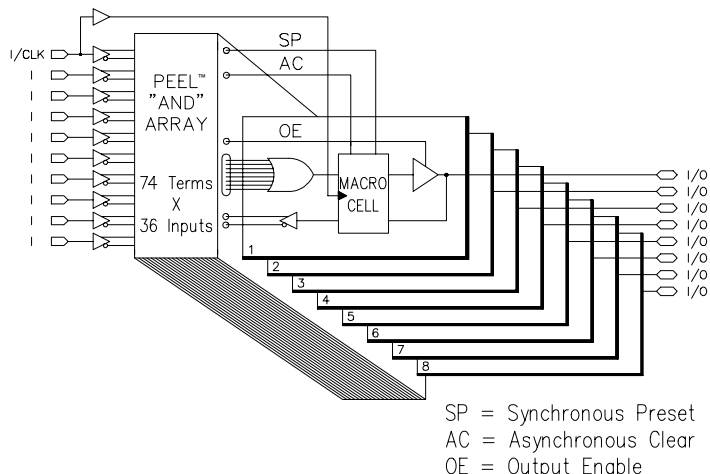

Figure 3 Block Diagram



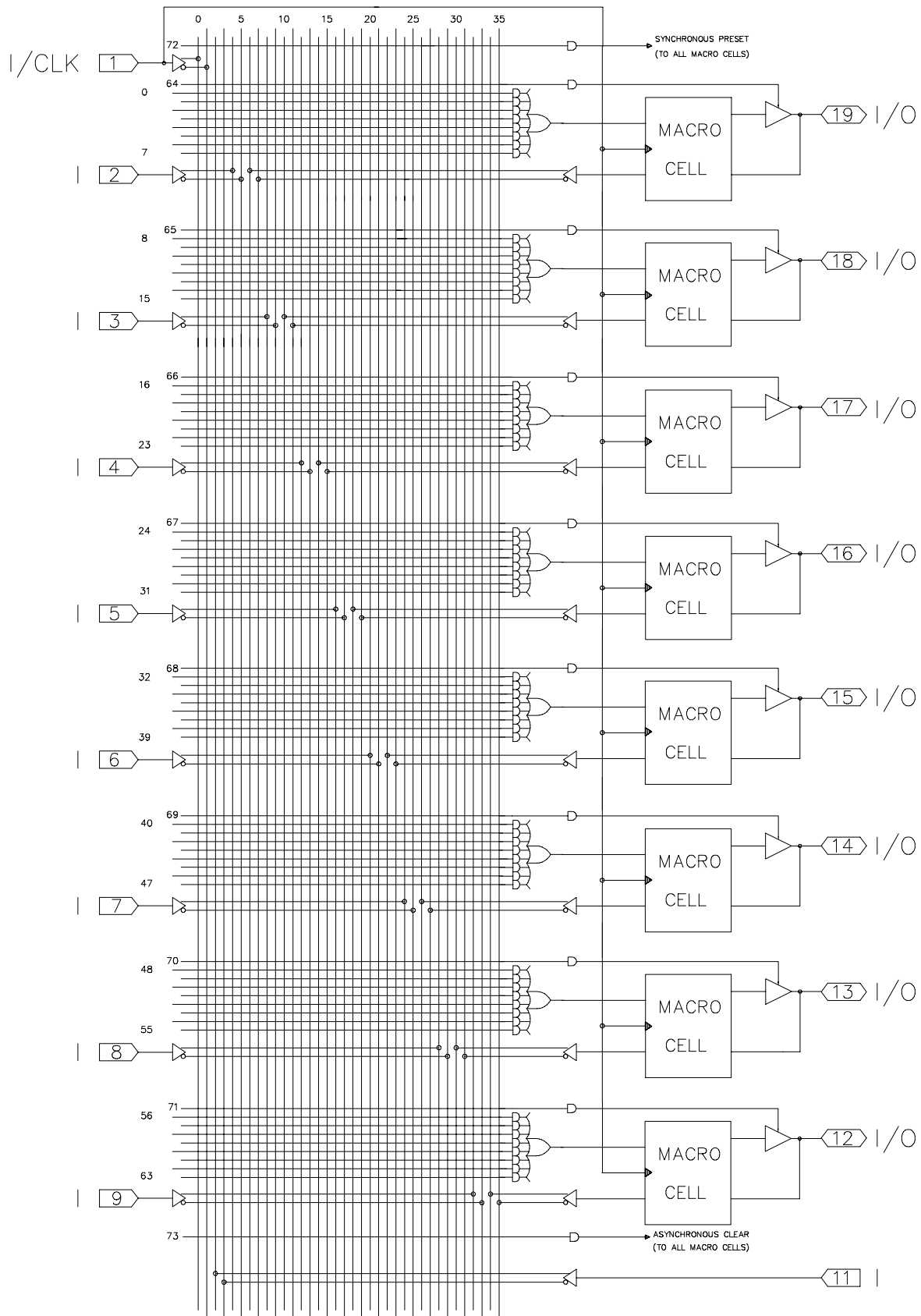

Figure 4 PEEL™18CV8 Logic Array Diagram



Function Description

The PEEL™18CV8 implements logic functions as sum-of-products expressions in a programmable-AND/fixed-OR logic array. User-defined functions are created by programming the connections of input signals into the array. User-configurable output structures in the form of I/O macrocells further increase logic flexibility.

Architecture Overview

The PEEL™18CV8 architecture is illustrated in the block diagram of Figure 3. Ten dedicated inputs and 8 I/Os provide up to 18 inputs and 8 outputs for creation of logic functions. At the core of the device is a programmable electrically-erasable AND array which drives a fixed OR array. With this structure, the PEEL™18CV8 can implement up to 8 sum-of-products logic expressions.

Associated with each of the 8 OR functions is an I/O macrocell which can be independently programmed to one of 12 different configurations. The programmable macrocells allow each I/O to create sequential or combinatorial logic functions of active-high or active-low polarity, while providing three different feedback paths into the AND array.

AND/OR LOGIC ARRAY

The programmable AND array of the PEEL™18CV8 (shown in Figure 4) is formed by input lines intersecting product terms. The input lines and product terms are used as follows:

36 Input Lines:

- 20 input lines carry the true and complement of the signals applied to the 10 input pins
- 16 additional lines carry the true and complement values of feedback or input signals from the 8 I/Os

74 product terms:

- 64 product terms (arranged in groups of 8) are used to form sum of product functions
- 8 output enable terms (one for each I/O)
- 1 global synchronous preset term
- 1 global asynchronous clear term

At each input-line/product-term intersection, there is an EEPROM memory cell that determines whether or not there is a logical connection at that intersection. Each product term is essentially a 36-input AND gate. A product term that is connected to both the true and complement of an input signal will always be FALSE and thus will not affect the OR function that it drives. When all the connections on a product term are opened, a “don’t care” state exists and that term will always be TRUE. When programming the PEEL™18CV8, the device programmer first performs a bulk erase to remove the previous pattern. The erase cycle opens every logical connection in the array. The device is configured to perform the user-defined function by programming selected connections in the AND array. (Note that PEEL™ device programmers automatically program all of the connections on unused product terms so that they will have no

effect on the output function).

Programmable I/O Macrocell

The unique twelve-configuration output macrocell provides complete control over the architecture of each output. The ability to configure each output independently permits users to tailor the configuration of the PEEL™18CV8 to the precise requirements of their designs.

Macrocell Architecture

Each I/O macrocell, as shown in Figure 4, consists of a D-type flip-flop and two signal-select multiplexers. The configuration of each macrocell is determined by the four EEPROM bits controlling these multiplexers. These bits determine output polarity, output type (registered or non-registered) and input-feedback path (bidirectional I/O, combinatorial feedback). Refer to Table 1 for details.

Equivalent circuits for the twelve macrocell configurations are illustrated in Figure 4. In addition to emulating the four PAL-type output structures (configurations 3,4,9, and 10), the macrocell provides eight additional configurations. When creating a PEEL™ device design, the desired macrocell configuration generally is specified explicitly in the design file. When the design is assembled or compiled, the macrocell configuration bits are defined in the last lines of the JEDEC programming file.

Output Type

The signal from the OR array can be fed directly to the output pin (combinatorial function) or latched in the D-type flip-flop (registered function). The D-type flip-flop latches data on the rising edge of the clock and is controlled by the global preset and clear terms. When the synchronous preset term is satisfied, the Q output of the register will be set HIGH at the next rising edge of the clock input. Satisfying the asynchronous clear will set Q LOW, regardless of the clock state. If both terms are satisfied simultaneously, the clear will override the preset.

Output Polarity

Each macrocell can be configured to implement active-high or active-low logic. Programmable polarity eliminates the need for external inverters.

Output Enable

The output of each I/O macrocell can be enabled or disabled under the control of its associated programmable output enable product term. When the logical conditions programmed on the output enable term are satisfied, the output signal is propagated to the I/O pin. Otherwise, the output buffer is switched into the high-impedance state.

Under the control of the output enable term, the I/O pin can function as a dedicated input, a dedicated output, or a bi-directional I/O. Opening every connection on the output enable term will permanently enable the output buffer and yield a dedicated output. Conversely, if every connection is intact, the enable term will

always be logically false and the I/O will function as a dedicated input.

Input/Feedback Select

The PEEL™18CV8 macrocell also provides control over the feedback path. The input/feedback signal associated with each I/O macrocell may be obtained from three different locations; from the I/O input pin, from the Q output of the flip-flop (registered feedback), or directly from the OR gate (combinatorial feedback).

Bi-directional I/O

The input/feedback signal is taken from the I/O pin when using the pin as a dedicated input or as a bi-directional I/O. (Note that it is possible to create a registered output function with a bi-directional I/O.)

Combinatorial Feedback

The signal-select multiplexer gives the macrocell the ability to feedback the output of the OR gate, bypassing the output buffer, regardless of whether the output function is registered or combinatorial. This feature allows the creation of asynchronous latches, even when the output must be disabled. (Refer to configurations 5,6,7 and 8 in Figure 4.)

Registered Feedback

Feedback also can be taken from the register, regardless of whether the output function is to be combinatorial or registered. When implementing a combinatorial output function, registered feedback allows for the internal latching of states without giving up the use of the external output.

Design Security

The PEEL™18CV8 provides a special EEPROM security bit that prevents unauthorized reading or copying of designs programmed into the device. The security bit is set by the PLD programmer, either at the conclusion of the programming cycle or as a separate step, after the device has been programmed. Once the security bit is set it is impossible to verify (read) or program the PEEL™ until the entire device has first been erased with the bulk-erase function.

Programming Support

Anachip's JEDEC file translator allows easy conversion of existing 20 pin PLD designs to the PEEL™18CV8, without the need for redesign. Anachip also offers (for free) its proprietary Win-PLACE software, an easy-to-use entry level PC-based software development system.

Programming support includes all the popular third party programmers: BP Microsystems, System General, Logical Devices, and numerous others.

Figure 4 Block Diagram of the PEEL™18CV8 I/O Macrocell

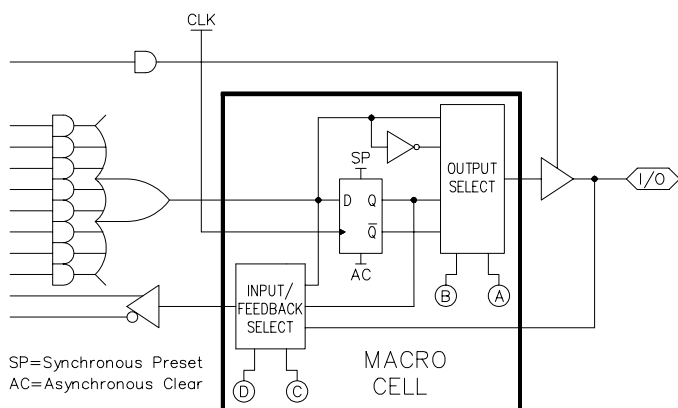

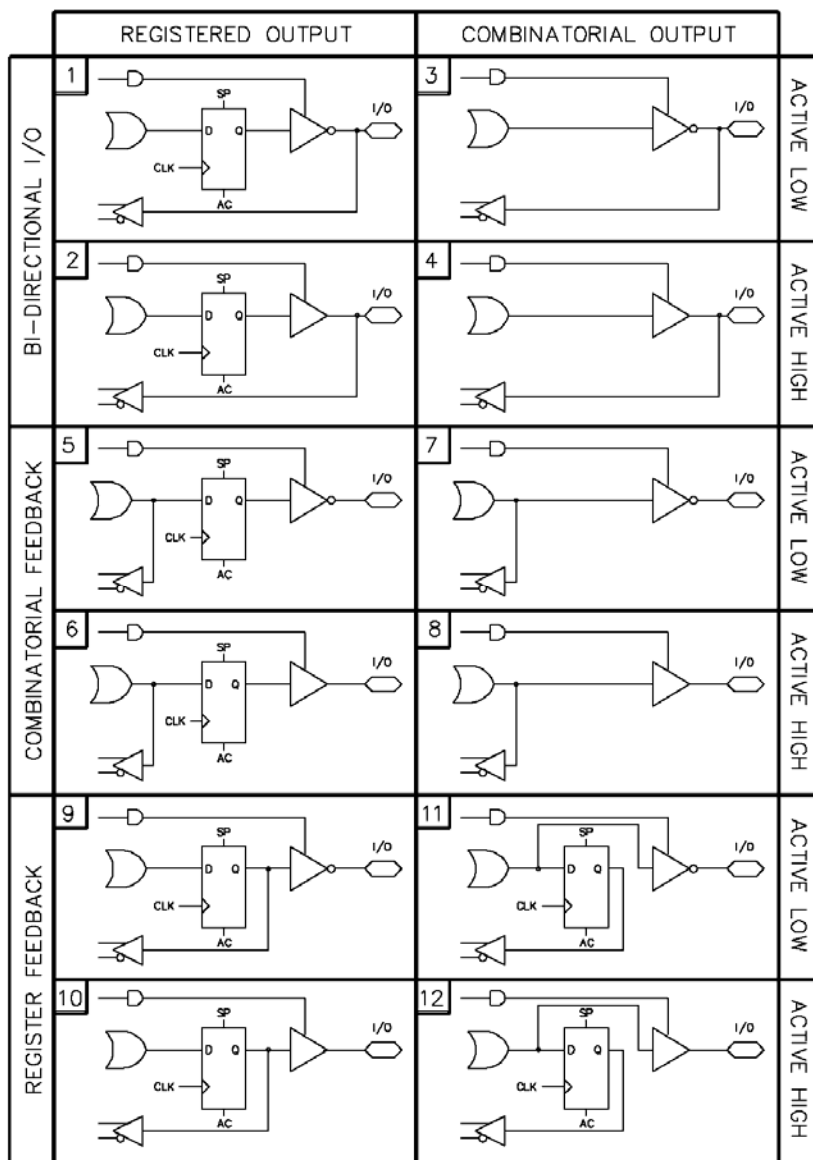

Figure 4 Equivalent Circuits for the Twelve Configurations of the PEEL™18CV8 I/O Macrocell

Configuration					Input/Feedback Select	Output Select	
#	A	B	C	D			
1	1	1	1	1	Bi-directional I/O	Register	Active Low
2	0	1	1	1			Active High
3	1	0	1	1		Combinatorial	Active Low
4	0	0	1	1			Active High
5	1	1	1	0	Combinatorial Feedback	Register	Active Low
6	0	1	1	0			Active High
7	1	0	1	0		Combinatorial	Active Low
8	0	0	1	0			Active High
9	1	1	0	0	Register Feedback	Register	Active Low
10	0	1	0	0			Active High
11	1	0	0	0		Combinatorial	Active Low
12	0	0	0	0			Active High



This device has been designed and tested for the specified operating ranges. Improper operation outside of these levels is not guaranteed. Exposure to absolute maximum ratings may cause permanent damage.

Absolute Maximum Ratings

Symbol	Parameter	Conditions	Rating	Unit
VCC	Supply Voltage	Relative to Ground	-0.5 to + 6.0	V
VI, VO	Voltage Applied to Any Pin ²	Relative to Ground ¹	-0.5 to VCC + 0.6	V
IO	Output Current	Per Pin (IOL, IOH)	±25	mA
TST	Storage Temperature		-65 to +150	°C
TLT	Lead Temperature	Soldering 10 Seconds	+300	°C

Operating Range

Symbol	Parameter	Conditions	Min	Max	Unit
Vcc	Supply Voltage	Commercial	4.75	5.25	V
		Industrial	4.5	5.5	V
T _A	Ambient Temperature	Commercial	0	+70	°C
		Industrial	-40	+85	°C
TR	Clock Rise Time	See Note 3.		20	ns
TF	Clock Fall Time	See Note 3.		20	ns
T _{RVCC}	V _{CC} Rise Time	See Note 3.		250	ms

D.C. Electrical Characteristics Over the operating range (Unless otherwise specified)

Symbol	Parameter	Conditions	Min	Max	Unit
VOH	Output HIGH Voltage - TTL	VCC = Min, IOH = -4.0 mA	2.4		V
VOHC	Output HIGH Voltage - CMOS ¹²	VCC = Min, IOH = -10 µA	VCC - 0.3		V
VOL	Output LOW Voltage - TTL	VCC = Min, IOL = 16mA/24mA ¹³		0.5	V
VOLC	Output LOW Voltage - CMOS ¹²	VCC = Min, IOL = 10 µA		0.15	V
VIH	Input HIGH level		2.0	VCC + 0.3	V
VIL	Input LOW Voltage		-0.3	0.8	V
IIL	Input, I/O Leakage Current LOW Input and I/O pull-ups disabled	VCC = Max, VIN = GND, I/O = High Z		-10	µA
IIP	Input, I/O Leakage Current LOW Input and I/O pull-ups enabled	VCC = Max, VIN = GND, I/O = High Z		-100	µA
IIH	Input, I/O Leakage Current HIGH	VCC = Max, VIN = VCC, I/O = High Z	0 (Typical)	40	µA
ISC ⁹	Output Short Circuit Current	VCC = 5V, VO = 0.5V, TA = 25°C	-30	-135	mA
ICC ¹⁰	VCC Current, f=25MHz	VIN = 0V or VCC, f = 25 MHz All Outputs disabled ⁴	-7	90	mA
			-10/I-10	90/100	
			-15/I-15	45/55	
			-25/I-25	37/50	
CIN ⁷	Input Capacitance	TA = 25°C, VCC = 5.0V @ f = 1 MHz		6	pF
COU ⁷	Output Capacitance			12	pF



A.C. Electrical Characteristics

Over the operating range ⁸

Symbol	Parameter	-7		-10/I-10		-15/I-15		-25/I-25		Units
		Min	Max	Min	Max	Min	Max	Min	Max	
t _{PD}	Input ⁵ to non-registered output		7.5		10		15		25	ns
t _{OE}	Input ⁵ to output enable ⁶		7.5		10		15		25	ns
t _{OD}	Input ⁵ to output disable ⁶		7.5		10		15		25	ns
t _{CO1}	Clock to Output		7		7		12		15	ns
t _{CO2}	Clock to comb. output delay via internal registered feedback		10		12		25		35	ns
t _{CF}	Clock to Feedback		3.5		4		8		15	ns
t _{SC}	Input ⁵ or feedback setup to clock	5		5		12		20		ns
t _{HC}	Input ⁵ hold after clock	0		0		0		0		ns
t _{CL} , t _{CH}	Clock low time, clock high time ⁸	3.5		5		10		15		ns
t _{CP}	Min clock period Ext (t _{SC} + t _{CO1})	12		12		24		35		ns
f _{MAX1}	Internal feedback (1/t _{SC} +t _{CF}) ¹¹	117.6		111		50		28.5		MHz
f _{MAX2}	External Feedback (1/t _{CP}) ¹¹	83.3		83.3		41.6		28.5		MHz
f _{MAX3}	No Feedback (1/t _{CL} +t _{CH}) ¹¹	142.8		100		50		33.3		MHz
t _{AW}	Asynchronous Reset Pulse Width	7.5		10		15		25		ns
t _{AP}	Input ⁵ to Asynchronous Reset		7.5		10		15		25	ns
t _{AR}	Asynchronous Reset recovery time		7.5		10		15		25	ns
t _{RESET}	Power-on reset time for registers in clear state		5		5		5		5	μs

Switching Waveforms

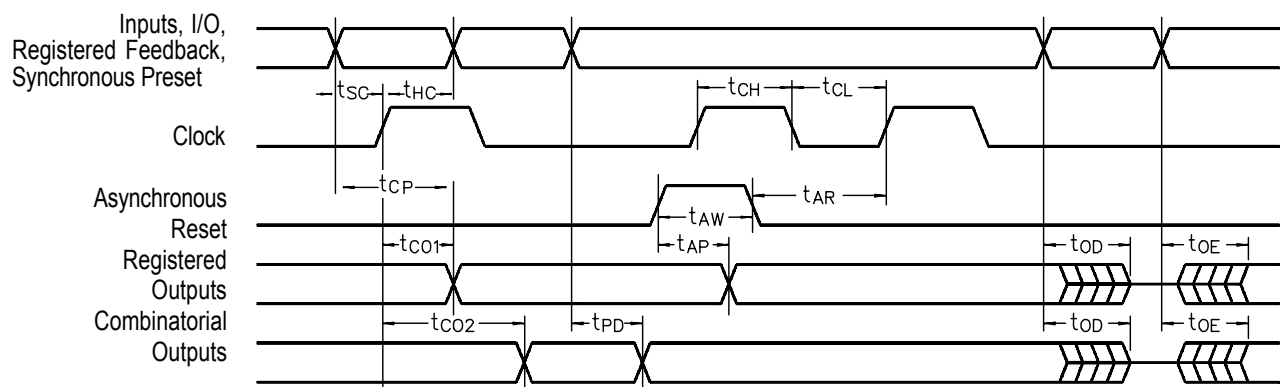

Notes:

1. Minimum DC input is -0.5V, however, inputs may undershoot to -2.0V for periods less than 20 ns.
2. VI and VO are not specified for program/verify operation.
3. Test Points for Clock and VCC in t_r and t_f are referenced at the 10% and 90% levels.
4. I/O pins are 0V and VCC.
5. "Input" refers to an input pin signal.
6. t_{OE} is measured from input transition to VREF±0.1V; t_{OD} is measured from input transition to VOH-0.1V or VOL+0.1V; VREF=VL.
7. Capacitances are tested on a sample basis.

8. Test conditions assume: signal transition times of 3ns or less from the 10% and 90% points, timing reference levels of 1.5V (Unless otherwise specified).
9. Test one output at a time for a duration of less than 1 second.
10. ICC for a typical application: This parameter is tested with the device programmed as an 8-bit Counter.
11. Parameters are not 100% tested. Specifications are based on initial characterization and are tested after any design process modification that might affect operational frequency.
12. Available only for 18CV8 -15/I-15/-25/I-25 grades
13. 24mA available for 18CV8-5/-7. All other speeds are 16mA.

PEEL™ Device and Array Test Loads

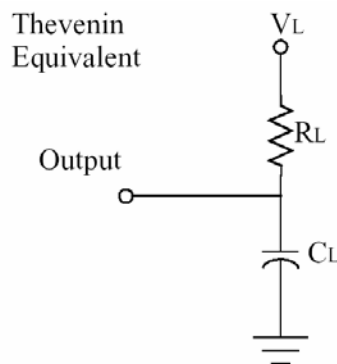
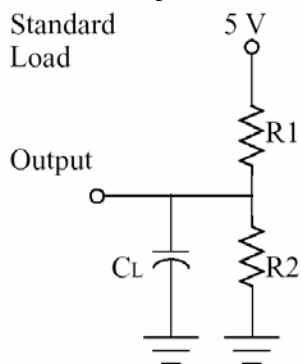

Technology	R1	R2	RL	VL	CL
CMOS ¹²	480kΩ	480kΩ	228kΩ	2.375V	33 pF
TTL -10/-15/-25	235Ω	159Ω	95Ω	2.02V	33 pF
TTL -5/-7	159Ω	118Ω	68Ω	2.129V	33 pF

Ordering Information

Part Number	Speed	Temperature	Package
PEEL18CV8P-7 (L)	7.5 ns	Commercial	20-pin Plastic 300 mil DIP
PEEL18CV8J-7 (L)	7.5 ns	Commercial	20-pin Plastic (J) Ledged Chip Carrier (PLCC)
PEEL18CV8S-7 (L)	7.5 ns	Commercial	20-pin SOIC
PEEL18CV8P-10 (L)	10 ns	Commercial	20-pin Plastic 300 mil DIP
PEEL18CV8PI-10 (L)		Industrial	
PEEL18CV8J-10 (L)	10 ns	Commercial	20-pin Plastic (J) Ledged Chip Carrier (PLCC)
PEEL18CV8JI-10 (L)		Industrial	
PEEL18CV8S-10 (L)	10 ns	Commercial	20-pin SOIC
PEEL18CV8SI-10 (L)		Industrial	
PEEL18CV8T-10 (L)	10 ns	Commercial	20-pin TSSOP 170 mil
PEEL18CV8TI-10 (L)		Industrial	
PEEL18CV8P-15 (L)	15 ns	Commercial	20-pin Plastic 300 mil DIP
PEEL18CV8PI-15 (L)		Industrial	
PEEL18CV8J-15 (L)	15 ns	Commercial	20-pin Plastic (J) Ledged Chip Carrier (PLCC)
PEEL18CV8JI-15 (L)		Industrial	
PEEL18CV8S-15 (L)	15 ns	Commercial	20-pin SOIC
PEEL18CV8SI-15 (L)		Industrial	
PEEL18CV8T-15 (L)	15ns	Commercial	20-TSSOP 170 mil
PEEL18CV8TI-15 (L)		Industrial	
PEEL18CV8P-25 (L)	25 ns	Commercial	20-pin Plastic 300 mil DIP
PEEL18CV8PI-25 (L)		Industrial	
PEEL18CV8J-25 (L)	25 ns	Commercial	20-pin Plastic (J) Ledged Chip Carrier (PLCC)
PEEL18CV8JI-25 (L)		Industrial	
PEEL18CV8S-25 (L)	25 ns	Commercial	20-pin SOIC
PEEL18CV8SI-25 (L)		Industrial	
PEEL18CV8T-25 (L)	25 ns	Commercial	20-pin TSSOP 170 mil
PEEL18CV8TI-25 (L)		Industrial	



Part Number

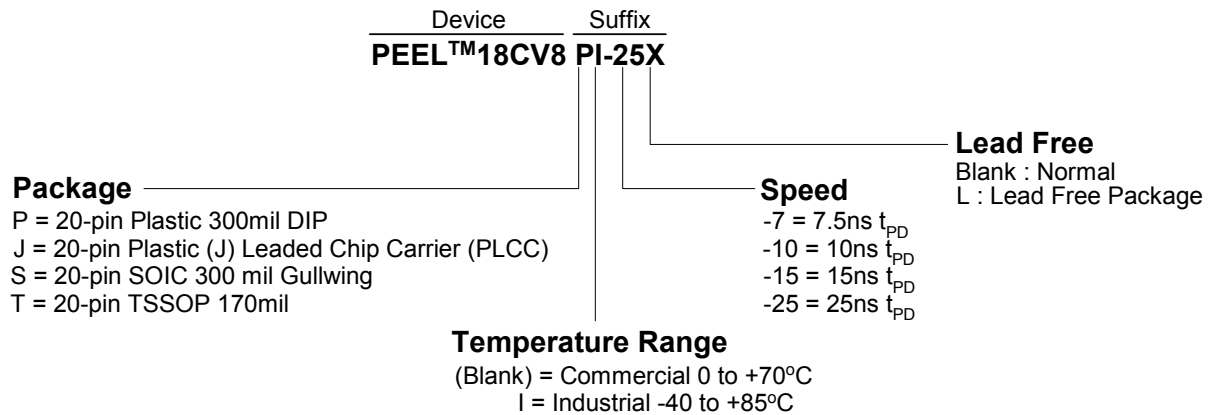

Anachip Corp.
 Head Office,
 2F, No. 24-2, Industry E. Rd. IV, Science-Based
 Industrial Park, Hsinchu, 300, Taiwan
 Tel: +886-3-5678234
 Fax: +886-3-5678368

Anachip USA
 780 Montague Expressway, #201
 San Jose, CA 95131
 Tel: (408) 321-9600
 Fax: (408) 321-9696

Email: sales_usa@anachip.com
 Website: <http://www.anachip.com>

©2004 Anachip Corp.

Anachip reserves the right to make changes in specifications at any time and without notice. The information furnished by Anachip in this publication is believed to be accurate and reliable. However, there is no responsibility assumed by Anachip for its use nor for any infringements of patents or other rights of third parties resulting from its use. No license is granted under any patents or patent rights of Anachip. Anachip's products are not authorized for use as critical components in life support devices or systems.

Marks bearing © or ™ are registered trademarks and trademarks of Anachip Corp.